



Technical Documents

1: Drawings DF603

2: Flashings Technical Specifications

*Follow
Us On*



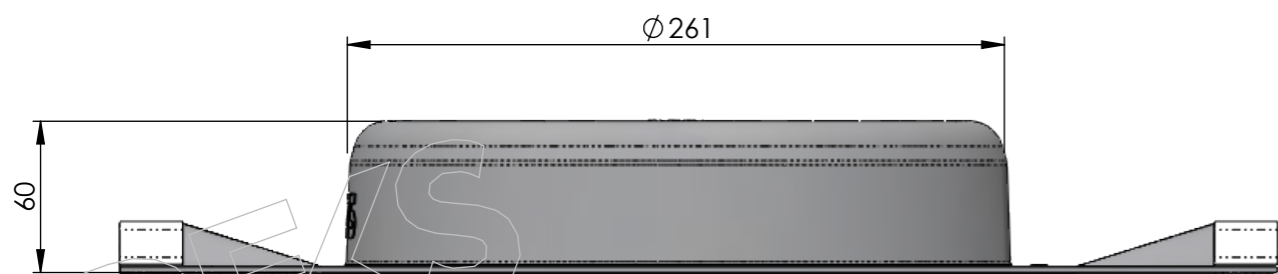
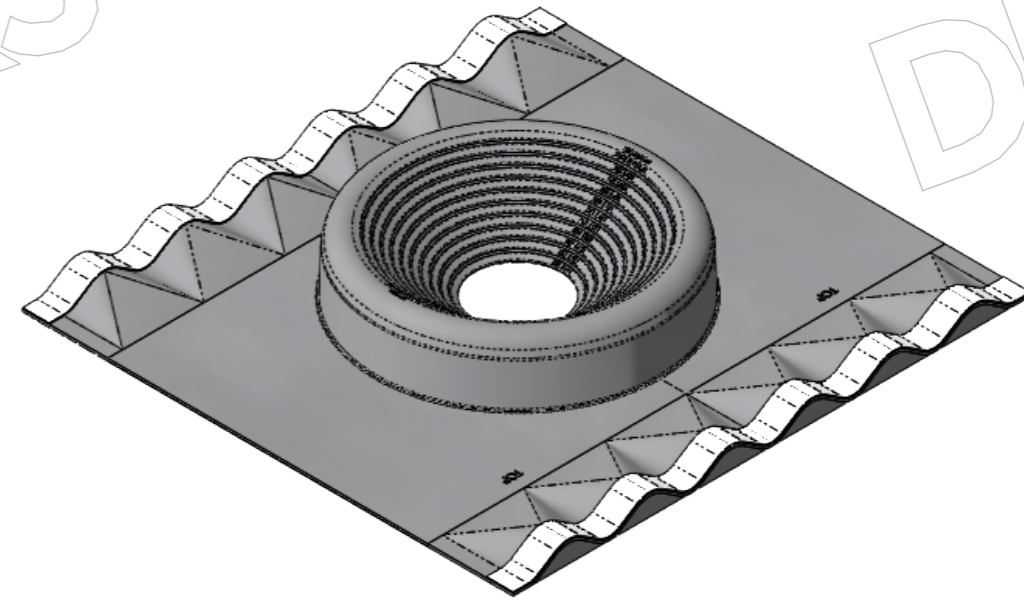
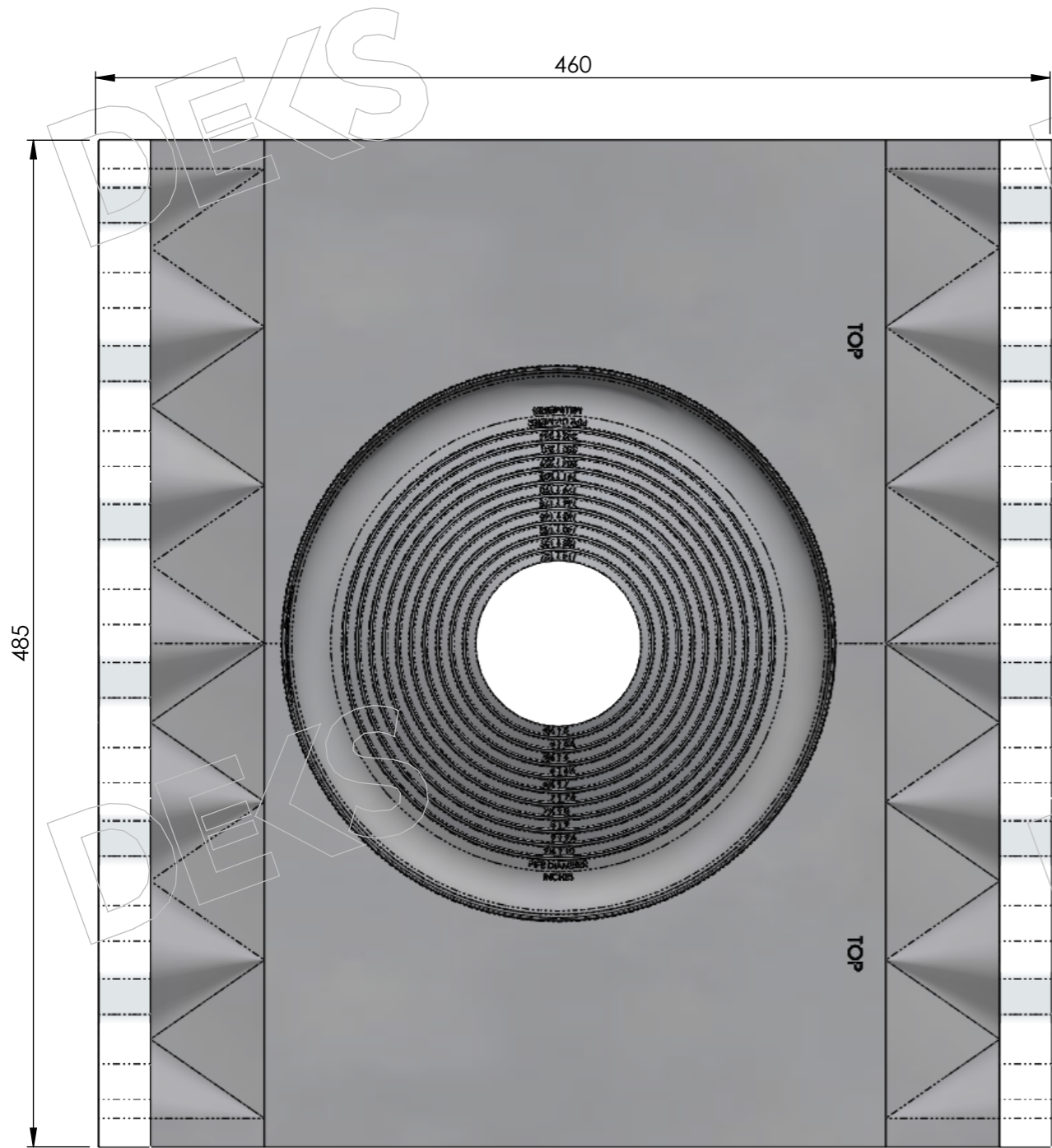

PART NUMBER	DISPLAY NAME	MATERIAL
DF603	Dektite Soaker #3 Gry (114-254mm/4.5-10")	EPDM/ALU
DF703	Dektite Soaker #3 Red Sil (114-254mm/4.5-10")	SILICONE/ALU

DEKS Industries Pty. Ltd.
ABN 77 107 135 544

5/841 Mountain Highway
PO Box 569
Bayswater Victoria
3153 Australia

TECHNICAL SPECIFICATION

PRODUCT RANGE: Dektite Soaker Flashings

Working Temperature:

Black and Grey EPDM -50°C (-122°F) to 115°C (239°F) and Red Silicone -50°C (-122°F) to 200°C (392°F)

Property	Conditions	Method	Requirements As per IAPMO PS 64 -12	Result
Ultimate Elongation of Rubber	Die C	ASTM D412	Min. 210 % Elongation	Complies
Split Tear Strength of Rubber	Die C	ASTM D624	Min. 0.25 kN/m (EPDM), Min. 0.17 kN/m (Silicone)	Complies
Water Absorption of Rubber	48 hrs @ 158°F	ASTM D471	Max. change 5% by volume	Complies
Ozone Resistance of Rubber	72 hrs @ 104°F & 50 pphm Ozone	ASTM D1149 and D1171	No visible cracks	Complies
Low Temp. Brittleness of Rubber	Non-brittle 3 minutes @ -40°F, Method A	ASTM D2137	No brittleness	Complies
UV resistance of Rubber	UV: One cycle of 4 hrs @ 140°F. Condensation: 2000 hrs @ 122°F	ASTM G154	Max. 50% loss in Tensile Strength & Elongation	Complies